

Metal forming technology for nanostructuring of light alloys

Andrzej Rosochowski, University of Strathclyde, Glasgow, UK

- **Potential global economic impact of nanostructured materials and their processing by 2011: \$340B (Hitachi Research Institute)**
- **Ultrafine grained (UFG) metals produced by severe plastic deformation (SPD)**
 - **Applications of UFG metals**
 - **Batch SPD processes**
 - **Continuous SPD processes**
 - **Concluding remarks**

Metal forming technology for nanostructuring of light alloys

- Applications
 - Sputtering targets
 - Medical implants

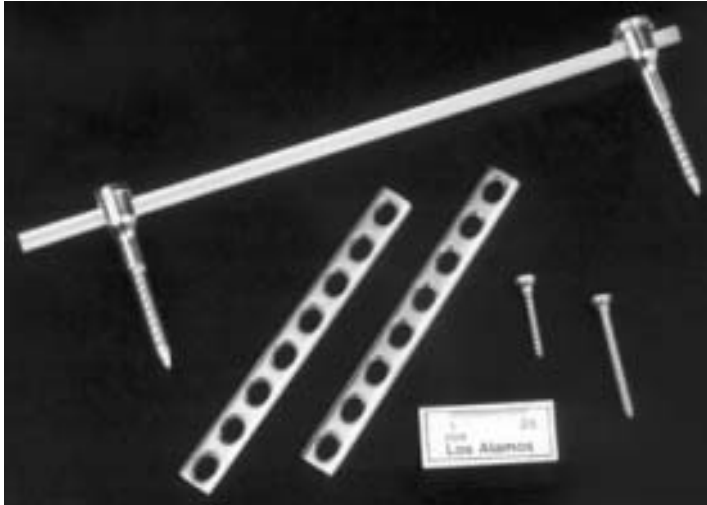

Los Alamos National Laboratory



Honeywell Electronic Materials

Metal forming technology for nanostructuring of light alloys

- Applications

- Self piercing rivets
- Warm forging

UFG Al 6061
315°C



UFG Al 6061
393°C

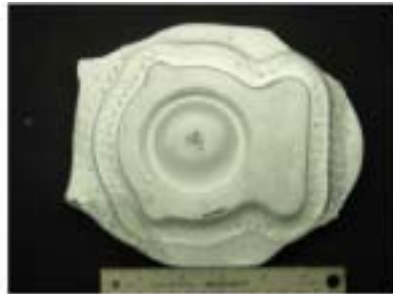

Wright State University



UFG Al 5083

Metal forming technology for nanostructuring of light alloys

- Applications
 - Microforming

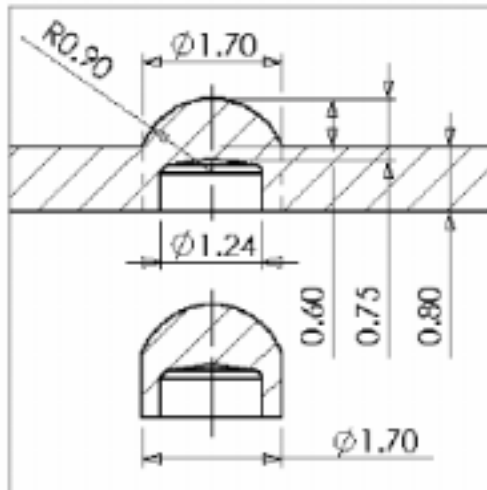

- Micromilling

Al 1070

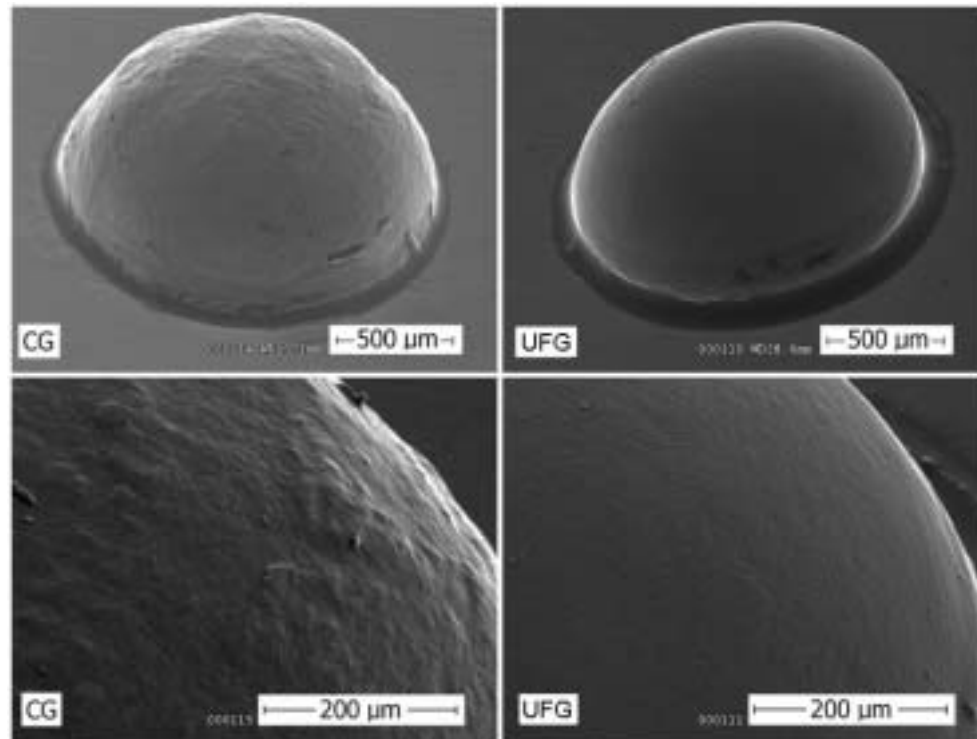

Metal forming technology for nanostructuring of light alloys

- Severe plastic deformation
 - Plastic strain > 3
 - No dimensional changes
 - No fracture
 - No texture
- New discipline of metal forming technology
 - Batch processes
 - Continuous processes

Metal forming technology for nanostructuring of light alloys

- Batch SPD processes

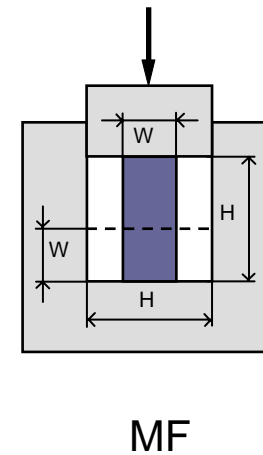
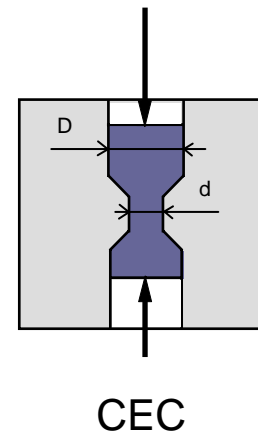
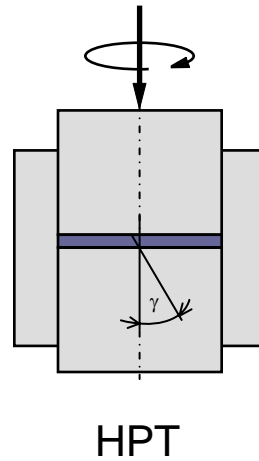
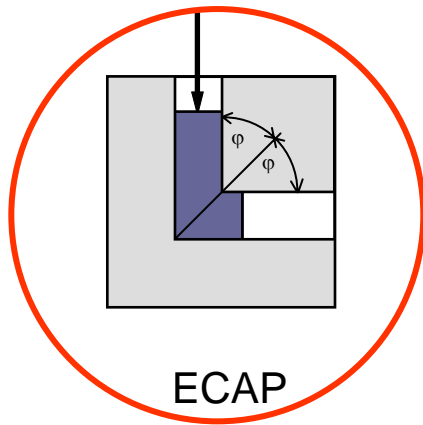

Metal forming technology for nanostructuring of light alloys

- Batch SPD processes
 - ECAP

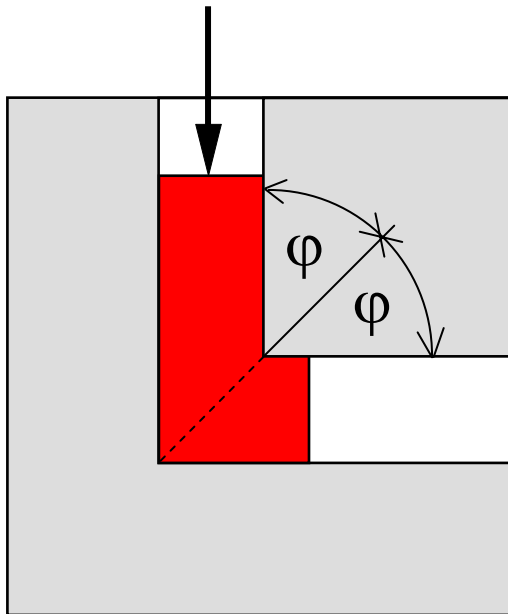

$$\varepsilon = 1.15$$

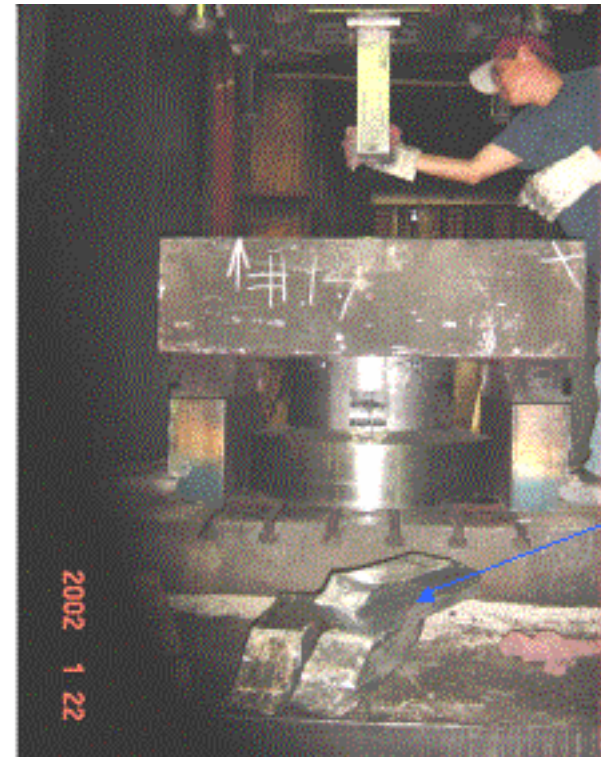

Wright State University

Metal forming technology for nanostructuring of light alloys

- Batch SPD processes
 - Multi-billet ECAP

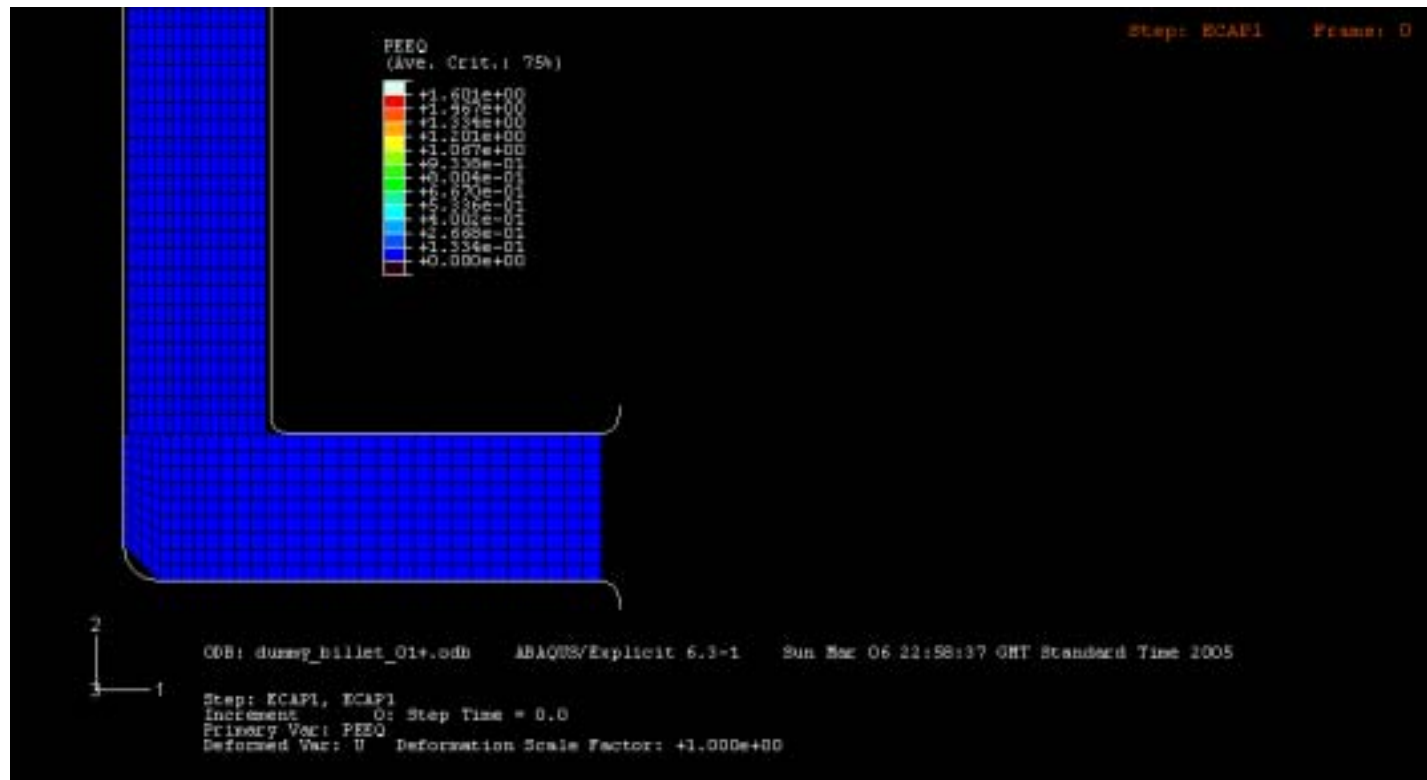

Metal forming technology for nanostructuring of light alloys

- Batch SPD processes
 - Rotation of billets between ECAP passes

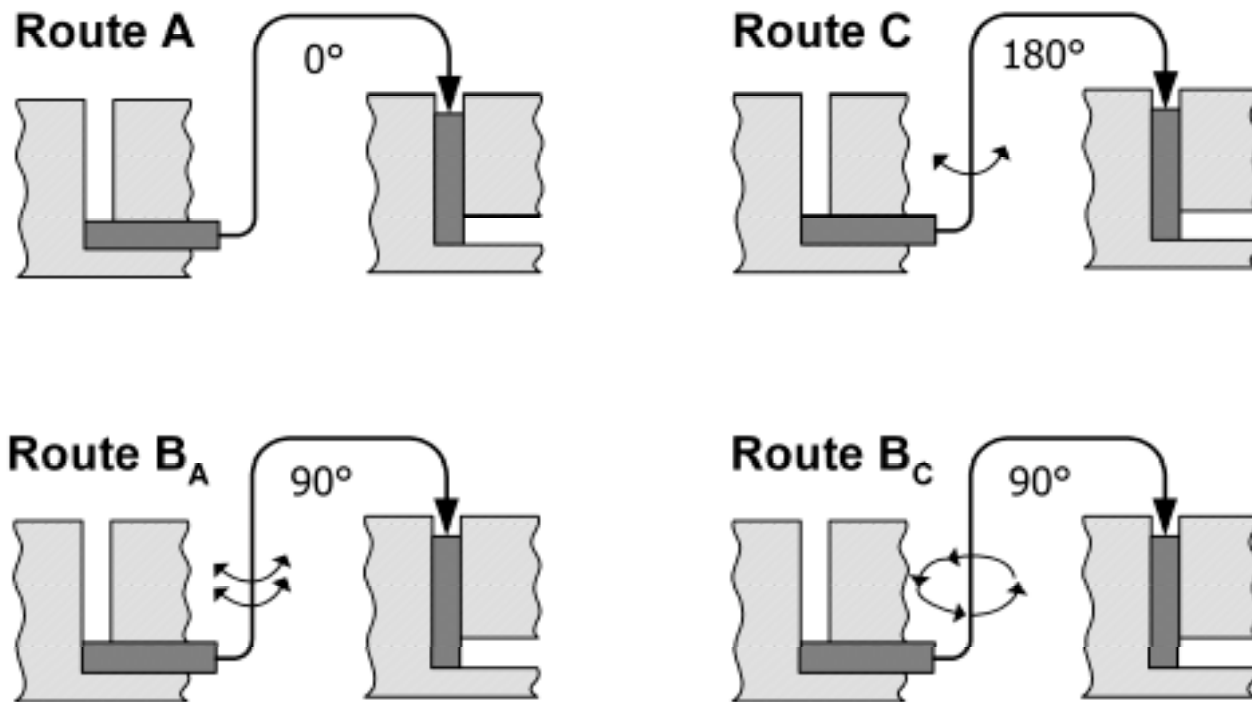

Metal forming technology for nanostructuring of light alloys

- Batch SPD processes
 - Multi-turn ECAP

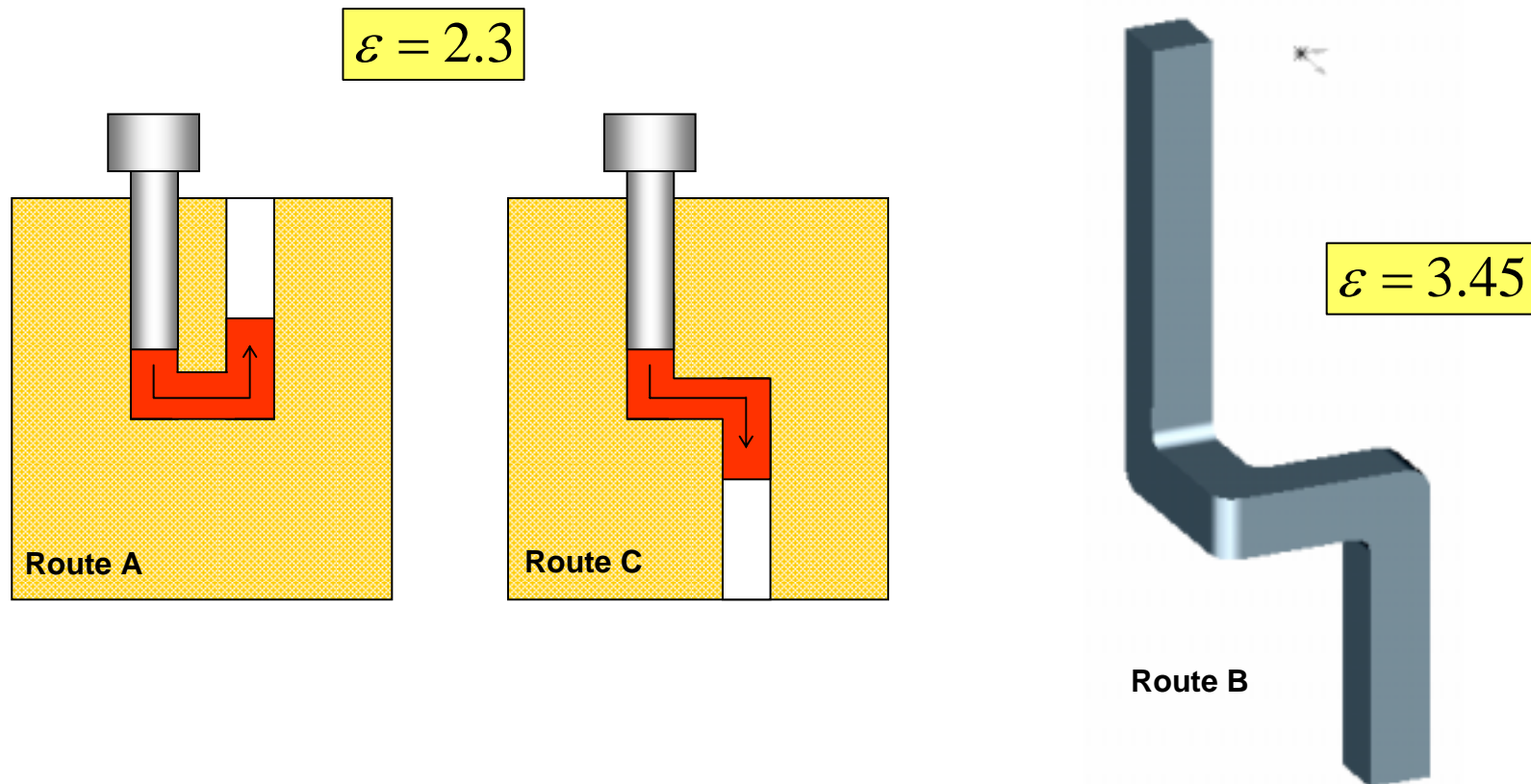

Metal forming technology for nanostructuring of light alloys

- Batch SPD processes
 - Multi-turn 3D ECAP

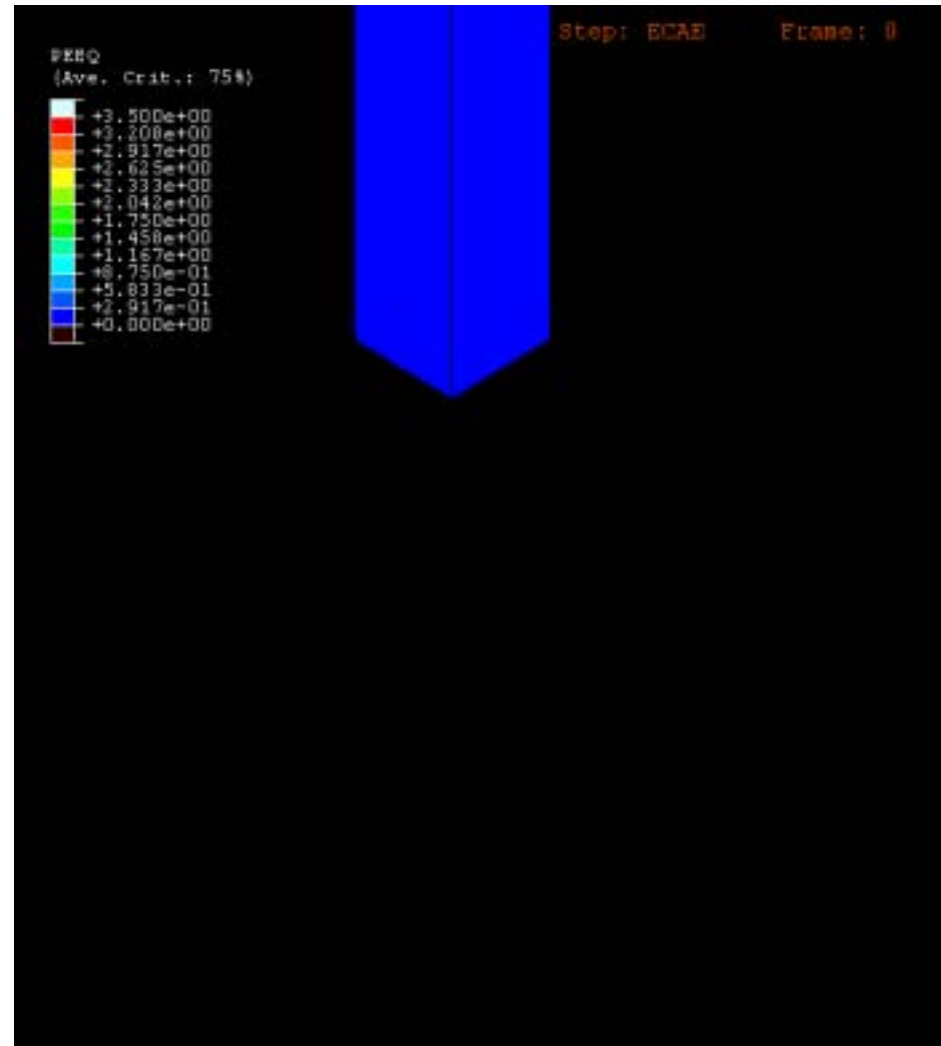

Metal forming technology for nanostructuring of light alloys

- Batch SPD processes
 - Multi-turn 3D ECAP

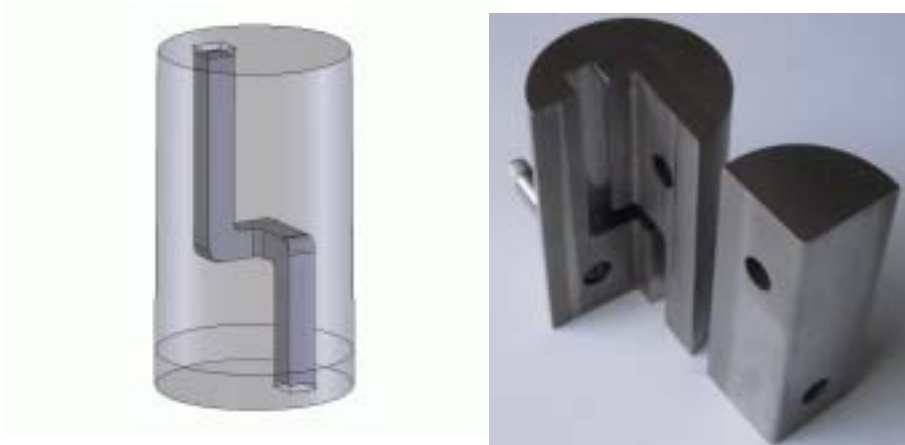

Metal forming technology for nanostructuring of light alloys

- Batch SPD processes
 - Multi-punch ECAP

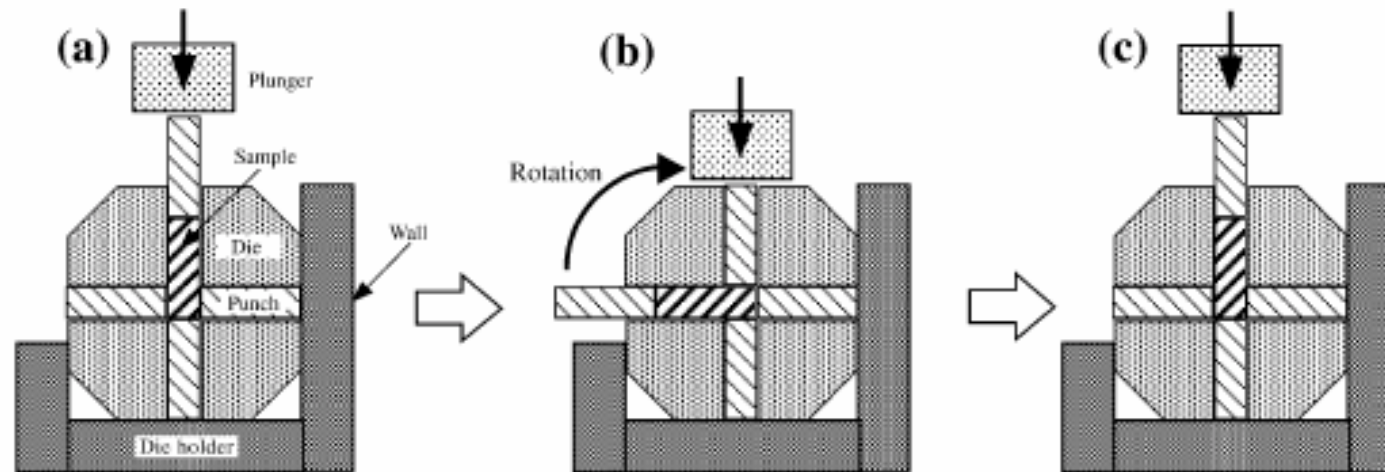

Metal forming technology for nanostructuring of light alloys

- Batch SPD processes
 - Multi-punch ECAP

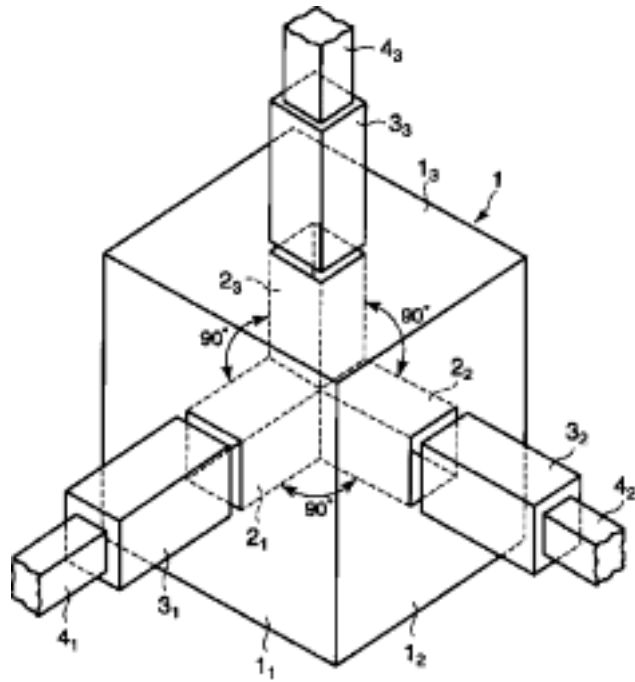

JP 2003019532 A

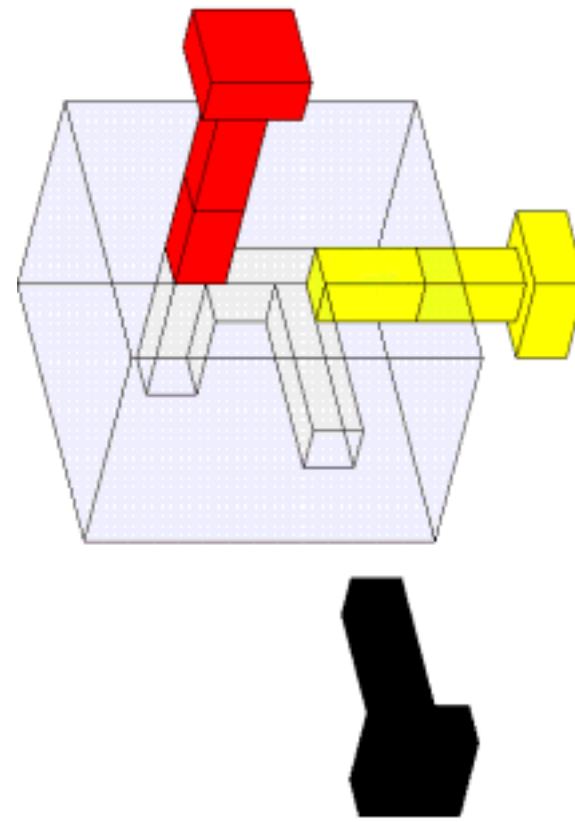

Metal forming technology for nanostructuring of light alloys

- Batch SPD processes
 - ECAP with moving die walls

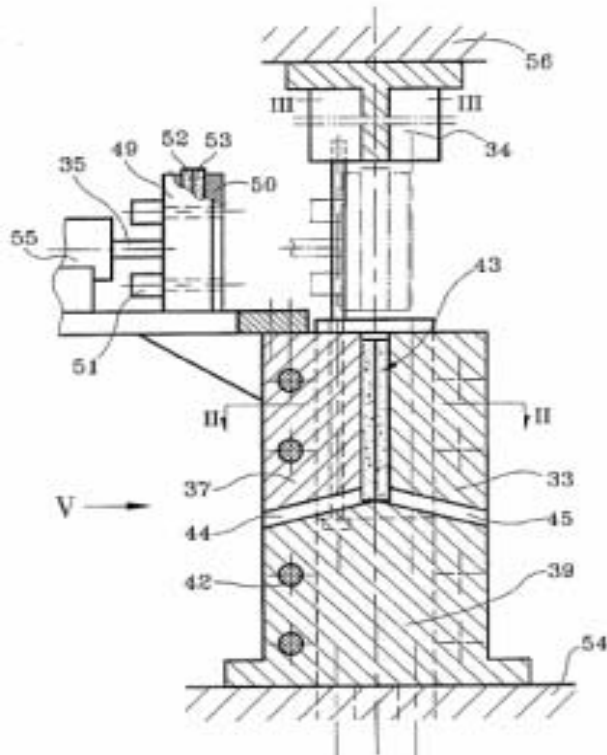

US Patent 5,600,989

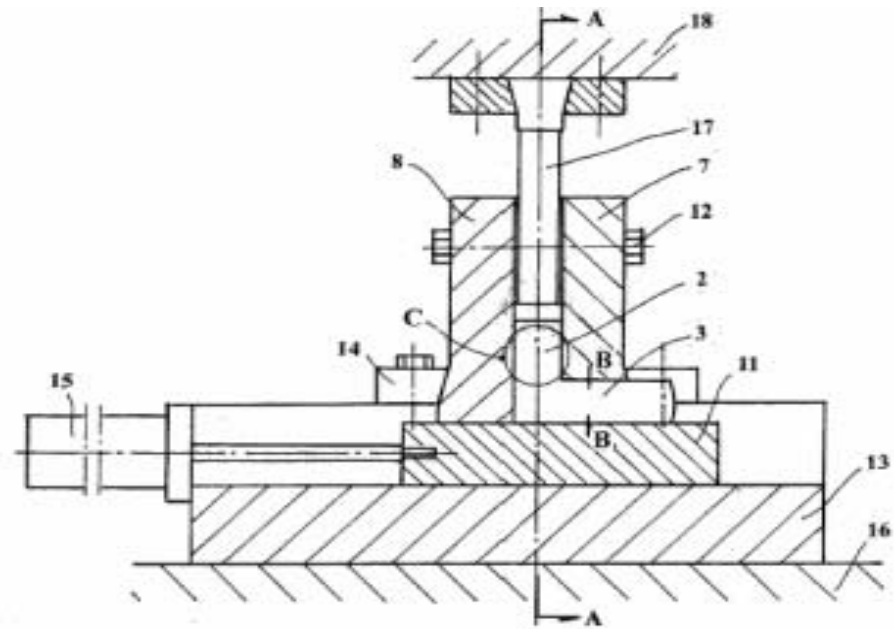

US 2005/0016243 A1

Metal forming technology for nanostructuring of light alloys

- Batch SPD processes
 - High pressure torsion

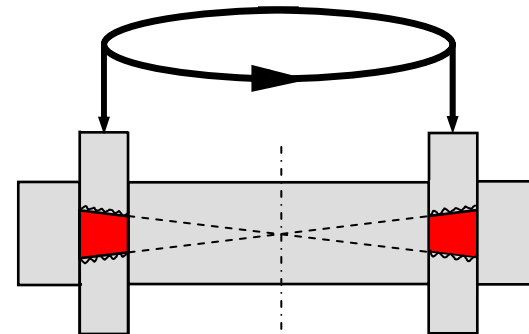
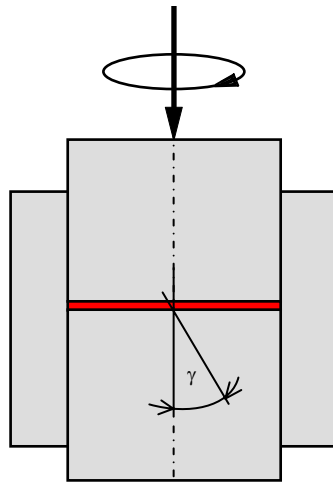

Metal forming technology for nanostructuring of light alloys

- Batch SPD processes
 - Twist extrusion

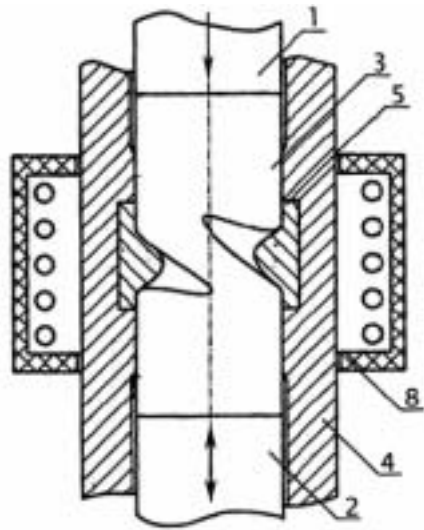

US 2004/0112112 A1

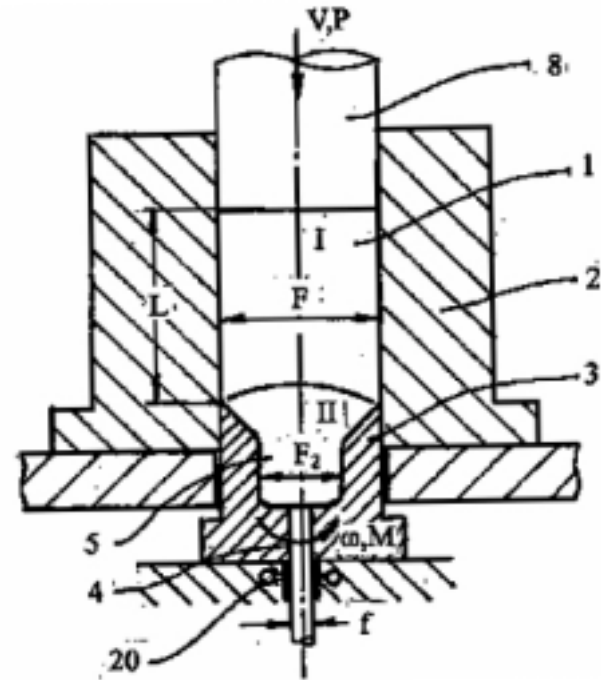

US 2005/0081594 A1

Metal forming technology for nanostructuring of light alloys

- Batch SPD processes
 - Multi axial forging

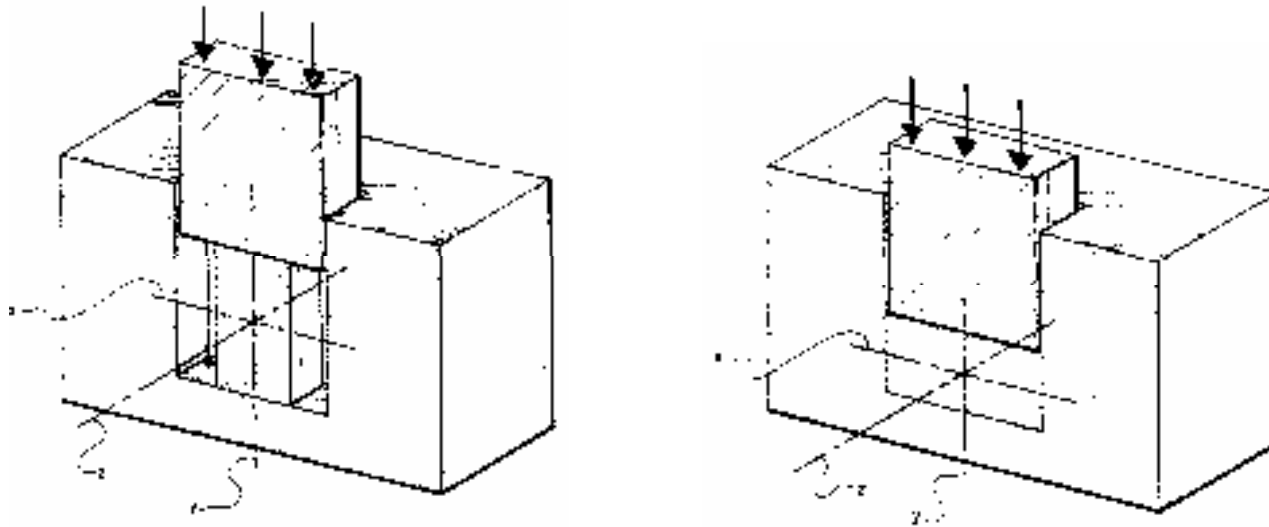

US Patent 4,721,537

Metal forming technology for nanostructuring of light alloys

- Continuous SPD processes
 - ECAP with continuous feeding - CONFORM type

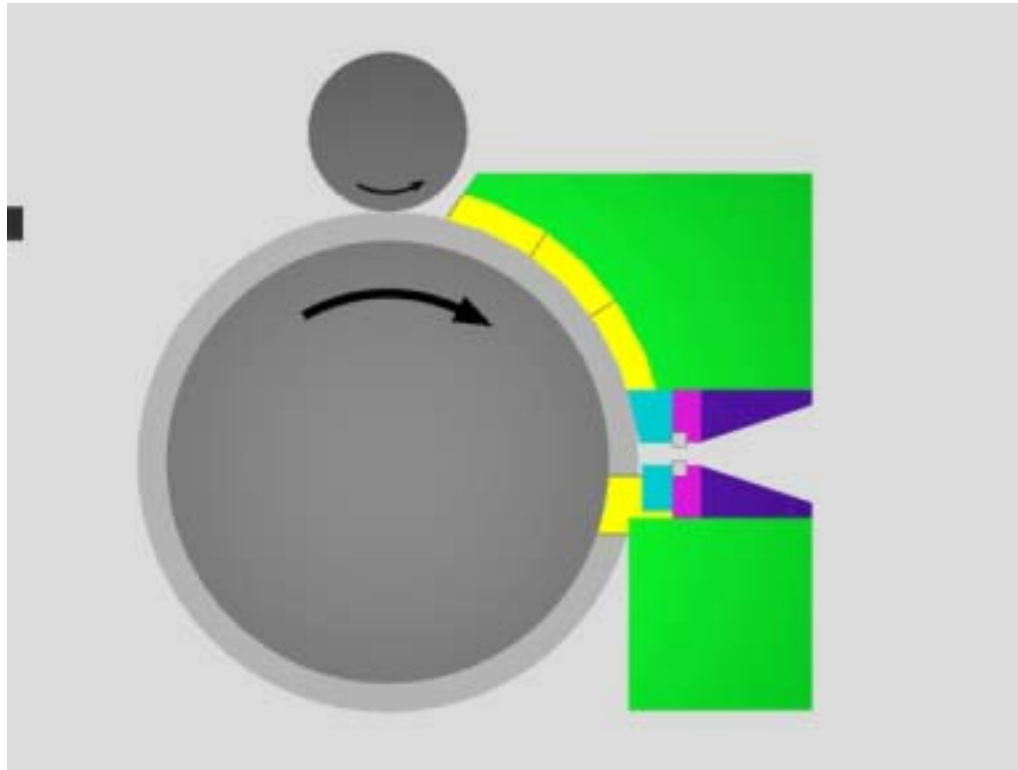

Autokumpu Holton

Metal forming technology for nanostructuring of light alloys

- Continuous SPD processes
 - ECAP with continuous feeding - CONFORM type

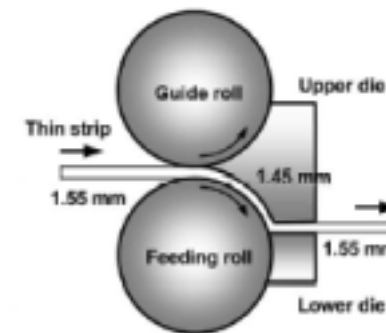
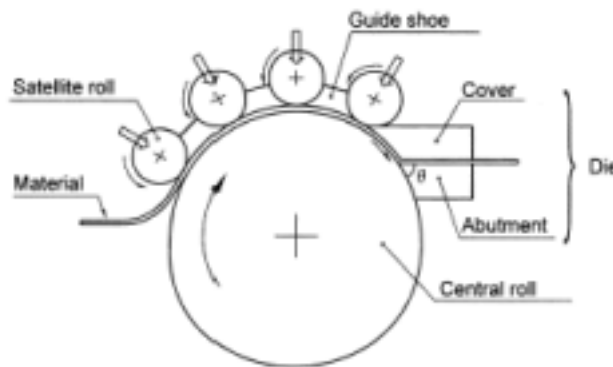
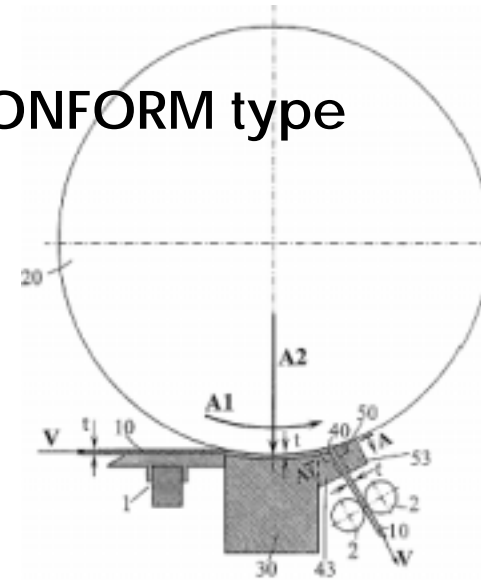
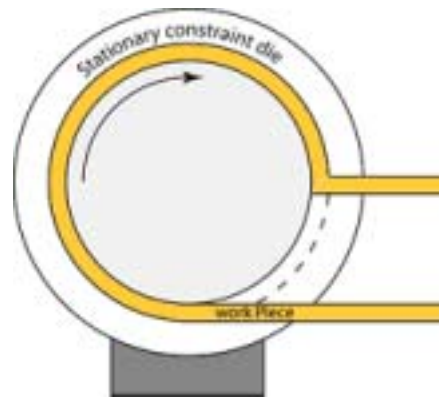

Metal forming technology for nanostructuring of light alloys

- Continuous SPD processes
 - ECAP with continuous feeding - Strathclyde type



Metal forming technology for nanostructuring of light alloys

- Continuous SPD processes
 - Repetitive corrugation and straightening

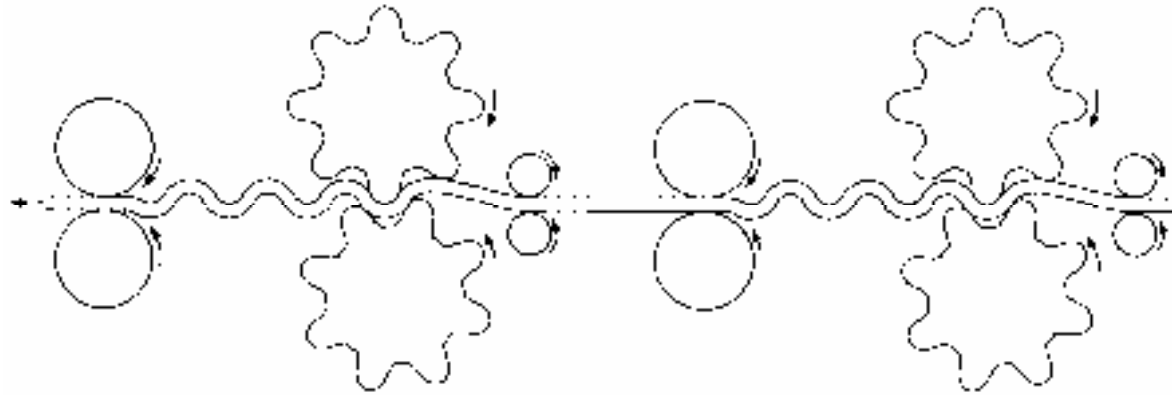

WO 2003/027337 A1

Metal forming technology for nanostructuring of light alloys

- Continuous SPD processes
 - Accumulative roll bonding

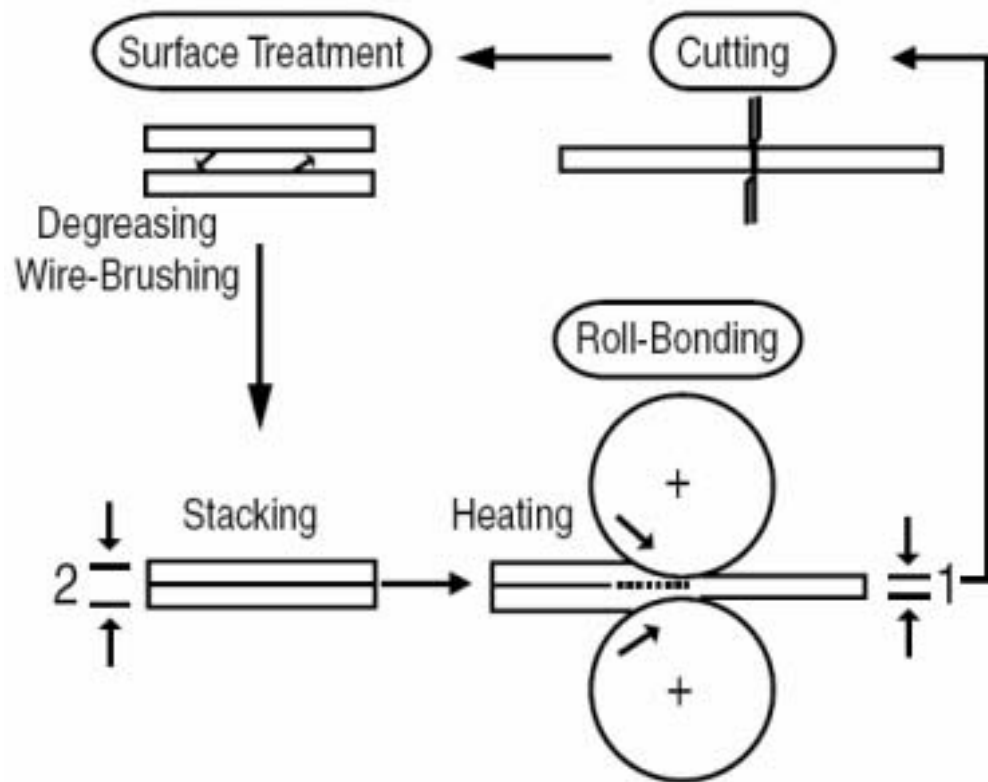

Metal forming technology for nanostructuring of light alloys

- **Conclusions**

- A new discipline of metal forming technology is being born
- SPD refines grain structure without changing billet dimensions
- A dominant SPD process is ECAP
- Continuous processes are more likely to find practical applications
- SPD processes suffer from the same problems as classical metal forming processes
- SPD processes are accompanied by heat treatment and post-SPD shaping