



Using Physics-based Models to Improve Rolling Processes

By CJ Davenport, TWD Farley and JKH Smith, Innoval Technology Limited

In today's competitive marketplace and with continuing slow global economic growth, aluminium manufacturers are under constant pressure to improve their products and processes to deliver increased customer satisfaction and loyalty and, ultimately, greater financial returns. Companies are seeking to improve product quality, increase the utilisation of their machines and to reduce operating costs.

To achieve world-class product quality and machine performance often requires the solution of difficult problems. These may relate to the complexity of the product metallurgy, the evolution of the product surface during the process, the need for precise control of product dimensions and residual internal stresses or the need to overcome machine constraints.

To solve the most challenging problems requires a deep technical understanding provided only by experienced industry experts and this can be enhanced by the application of computer models for increased insight in the processes.

Innoval Rolling Model (IRM)

Many of the processes required to produce aluminium sheet are done out of sight where measurements of important process parameters are impossible. For example, during the rolling of sheet the strip thickness reduction and other dimensional changes which determine product quality occur in a tiny volume of the roll bite. This volume is only about 0.26 cm³/metre width when producing 45 micron foil.

It is important to understand what is happening in this small volume during rolling so that reasonable estimates can be made of rolling loads, torques, current drawn by the motors and the resultant strip temperature and profile. These factors are needed for the improvement of rolling practices and devising new schedules. This is best done by mathematical modelling and an example of some output from the Innoval Rolling Model is given below. Figure 1 shows the result of modelling a pass in a hot finishing mill rolling can end stock.

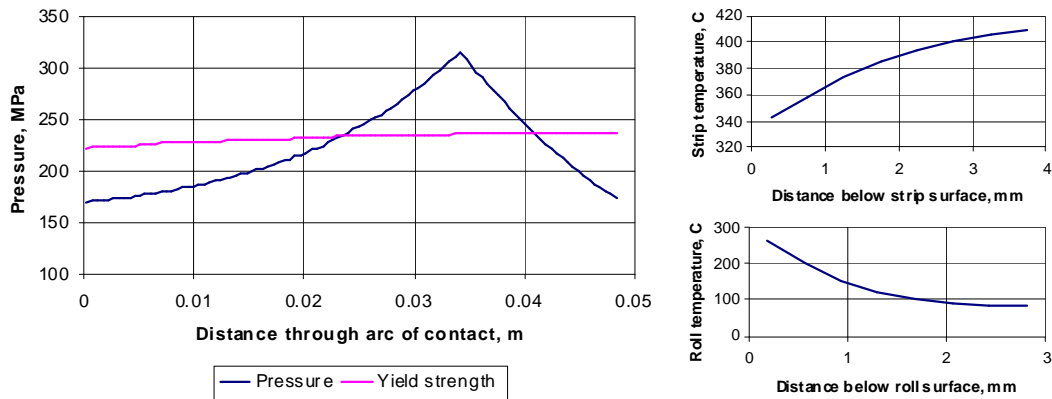

Figure 1. Modelled roll pressure and material flow stress with through-thickness strip and roll temperatures at the bite exit rolling a pass of can end stock

This shows the pressure distribution on the roll in the roll bite (the so-called friction hill) and forward slip, together with the through-thickness temperature variations for both strip and roll surfaces just as the strip leaves the bite. The heat from the strip into the rolls is determined not just by the conditions in the bite itself but also by the thermal conduction into the roll surface. The temperature gradient in the roll surface limits the heat transfer. There is an increasing use of rolls with low thermal conductivity, e.g. high speed steel rolls, which can have a profound effect on the heat flows in the rolling process. This sort of effect would be very difficult to identify without a physics-based model.

Figure 2 is a screen shot of the model output. The user can select any range of output parameters to view or print.

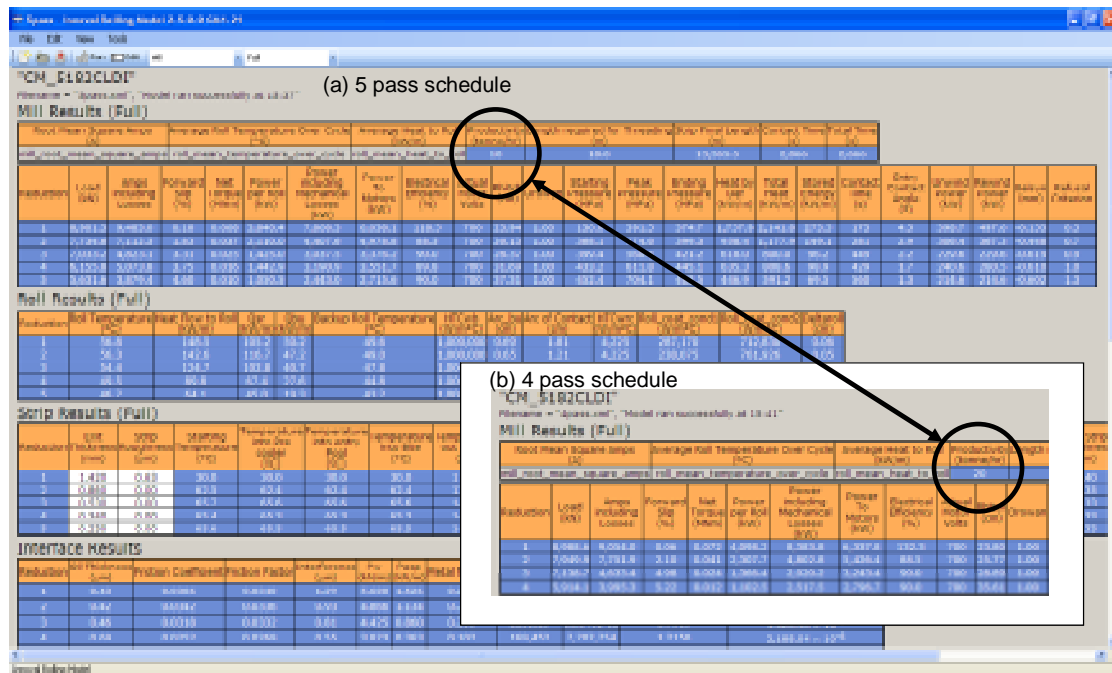

Figure 2 Sample output from the Innoval Rolling Model showing (a) a 5 pass can end stock rolling schedule with productivity 18 tonnes/hr and highlighting the predicted increased productivity of 20 tonnes/hr for a 4 pass schedule (see (b) insert).



This model can be used to design new rolling schedules for an existing mill and to estimate the maximum productivity from new mills before they are built or even fully specified. The proper use of a model of this kind can save many hundreds of hours of lost time compared with the use of less sophisticated approaches.

Innoval Spray Impingement Model (ISIM)

There is a continual drive to improve the quality of the product produced from rolling mills. This can be in the form of profile or flatness control performance, or indeed the surface quality. The coolant used in a modern mill performs multiple functions: It must remove heat from the rolls; provide lubrication to the rolling process and wash away debris which might otherwise give surface quality problems. The cooling system is also an important actuator in strip profile and flatness control by controlling the roll thermal camber. All these functions must be performed simultaneously.

A spray roll cooling configuration must dissipate sufficient heat from the rolling process to maintain appropriate work roll temperatures. These target roll temperatures are determined by the process and equipment in use: the need to plate oil onto the work roll for lubrication on hot mills; the need to develop sufficient temperature differential between the work roll and the applied coolant in cold rolling to have a thermal camber response when switching the sprays on and off, while at the same time avoiding steep thermal gradients at the strip edge.

For profile and flatness control the distribution of coolant across the roll width must be carefully controlled. It has been found that the axial interaction of nozzles across the work rolls affects the ability to control the thermal roll expansion locally. For this reason we apply a constraint to the overlap of spray patterns through the range of work roll diameters used on a mill stand. This variation may also have to account for variation in pass-line or structural mounting of the header that result from the roll diameter variation.

The Innoval Spray Impingement Model (ISIM) is used to determine the cooling effect of spray application to the mill work rolls. This cooling is a function of the sprayed area, the spray intensity, coolant media and positioning of the headers relative to one another around the roll circumference. This cooling effect has to dissipate sufficient heat, calculated from roll gap models, to maintain the target work roll temperature. Other model inputs include the speed of work roll rotation as the effect of roll surface chilling on circumferential roll surface temperature distribution is required to quantify the effective level of cooling. The units of heat transfer coefficient are W/m^2K thus the local coolant to work roll surface temperature difference determines the actual amount of heat dissipated.

If two spray patterns lie close together on the roll surface then it will not be possible to obtain the sum of the benefits of the banks acting separately. This is because of spray pattern interaction. The sprays from each bank interfere as they attempt to operate on the same area of the roll surface. This effect is included in the Model in order to calculate the total effect of groups of nozzle banks.

As the spray impingement patterns can be plotted on the roll surface, it is also possible to assess the level of overlap between the patterns in a single row. This can be compared with optimum ranges to avoid heat striping but to give the maximum actuator effect within the profile or flatness control systems.

Figure 3 shows an example output screen from ISIM showing various key results. Data report files for deeper analyses are also created.

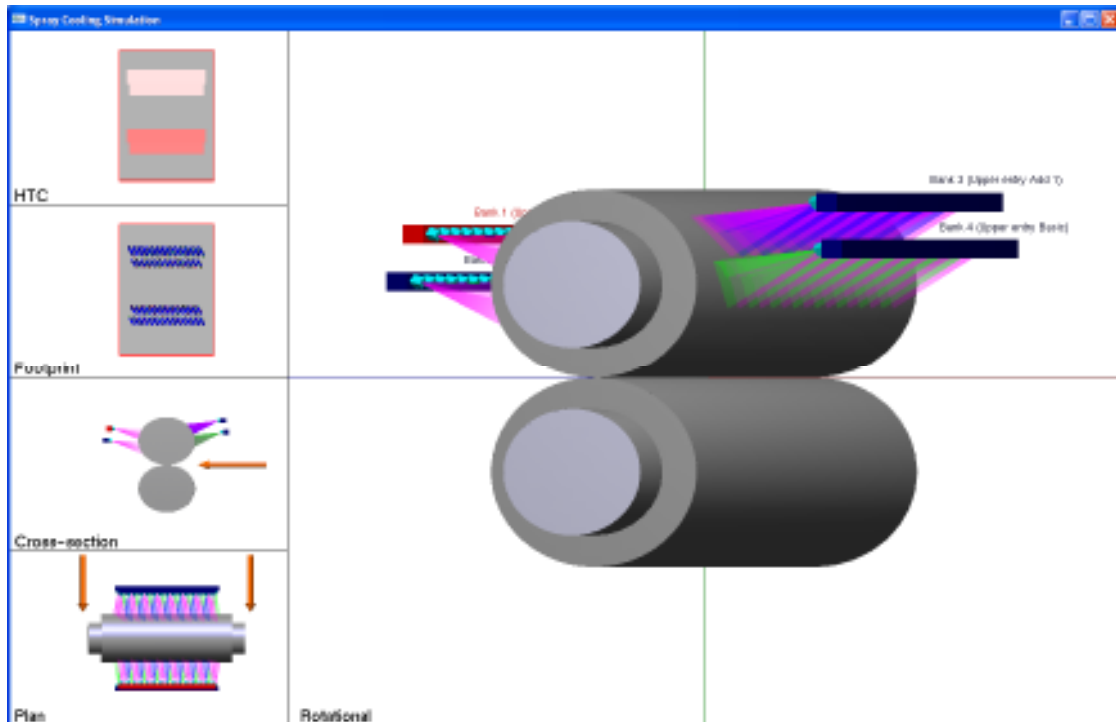

Figure 3. Innoval Spray Impingement Model output screen

Figure 4 shows a comparison of spray application on a hot mill before and after the model was used to improve the mill actuator performance. The spray impact patterns are calculated assuming the sprays impact with a cylindrical roll and then the total roll surface is unwrapped and displayed as a 2-dimensional rectangular map. The dotted lines indicate the axial nozzle spacing. Red, green and blue impact patterns indicate patterns that would be developed on minimum, nominal and maximum work roll diameters.

The spray impact patterns on the left can be seen to have significant axial pattern interactions and were the cause of limited actuator performance within a profile control scheme. The impact patterns on the right result from application of this Model and show that the sprays can be applied much more locally, producing less interaction and improving overall performance when used as a profile control actuator.

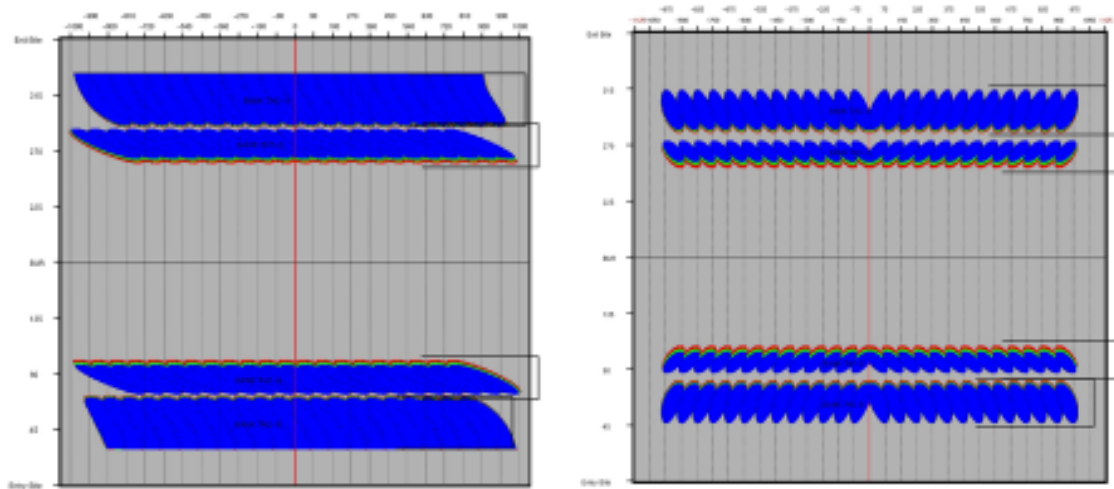

Figure 4. Predicted spray impact patterns on the work roll circumference. (left) large nozzle to nozzle interaction reducing actuator performance; (right) reconfigured arrangement for improved actuator performance

Innoval Ingot Preheating Models

Ingot pre-heating is another example of a rolling process stage where important parameters are hard to measure; in this case, the temperature deep inside the ingot. It is important during pre-heating for all parts of the ingot to reach the target temperature in order to achieve proper homogenisation. However, it is also important not to exceed the safe temperature on any parts of the ingot. This compromise can best be achieved by using a calibrated model. In this way, accurate temperature control can be achieved with a minimum time in the furnace.

Ingot pre-heating is the most energy-intensive part of the aluminium rolling process and models can be used to devise heating schedules for minimising the energy loss and also for identifying furnace defects. Figure 5 shows an output from the Innoval Pusher Furnace Model.

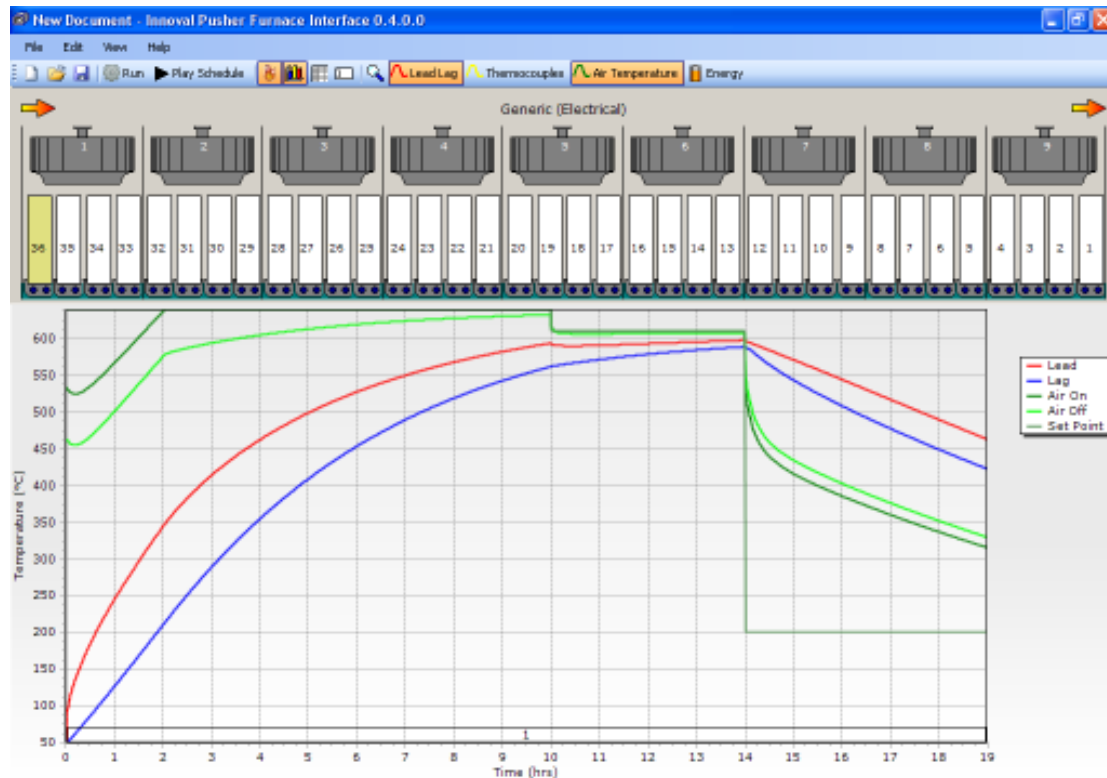

Figure 5. Output from the Innoval Pusher Furnace Model

This figure shows the temperature profile of single ingot progressing through the furnace. The ingot leading and lagging temperatures are plotted. These are the hottest and coldest locations anywhere within the ingot so all other parts lie between these two. Also shown are the set point temperature and the air temperature onto and off the furnace load. The model is able to predict in this case that near the beginning of the cycle the heating source is insufficient to maintain the air temperature at the set value. This happens when heat is being absorbed by the ingots and furnace structure at the highest rate. This model includes a calculation of the energy absorbed by the furnace structure itself and so can distinguish between hot and cold starting conditions. It is also possible to plot the energies for both the heating source and the fan used to circulate air round the furnace. This is useful for assessing the efficiency of the process including of the furnace itself.

A mathematical model of this type of furnace together with all the energy considerations can be used to minimise energy usage. This will usually coincide with a shortening of the heating cycle which will also improve the availability of ingots for processing. For example, the Model can be used to explore the effect of using higher heated air temperatures to accelerate the ingot heating at start of the preheating cycle.

Figure 6 shows how the Innoval Pit Preheat Model is used to reduce energy consumption during the preheating of 12 ingots, each of 9.1 tonnes, heated to a target temperature of 600C over a period of 20 hours. The leading and lagging ingot temperatures are shown, together with the gas energy and total energy consumed and the energy absorbed by the ingots. The total energy includes the electrical energy required to drive the air recirculation fan.

Figure 6 shows significantly higher than target air temperatures used at the beginning of the heat-up. The model indicates that for the time they are used there is no danger

of over-heating any part of the ingot. Because the model effectively can give warning of excess temperature anywhere on the ingot it allows a more aggressive heating regime which can enable a reduction in overall heating time without danger of damaging the ingot. The modelling showed that the ingots become available for rolling 2 hours earlier and consume 4GJ less energy when compared to more conservative set-air temperatures. This represents a significant energy saving.

This technique pre-supposes that there is sufficient power in the burners to maintain the air temperature at or near its set value. It is important to include the power limits in the modelling and thus model the actual air temperature, not just the set value. The problem of power limitation is most acute at the start of the cycle when the ingots and furnace structure can absorb heat at a high rate because they are relatively cold. Maintaining the correct set air temperature is also more of an issue in indirectly fired furnaces where there is no direct contact between the combustion products and the re-circulating air.

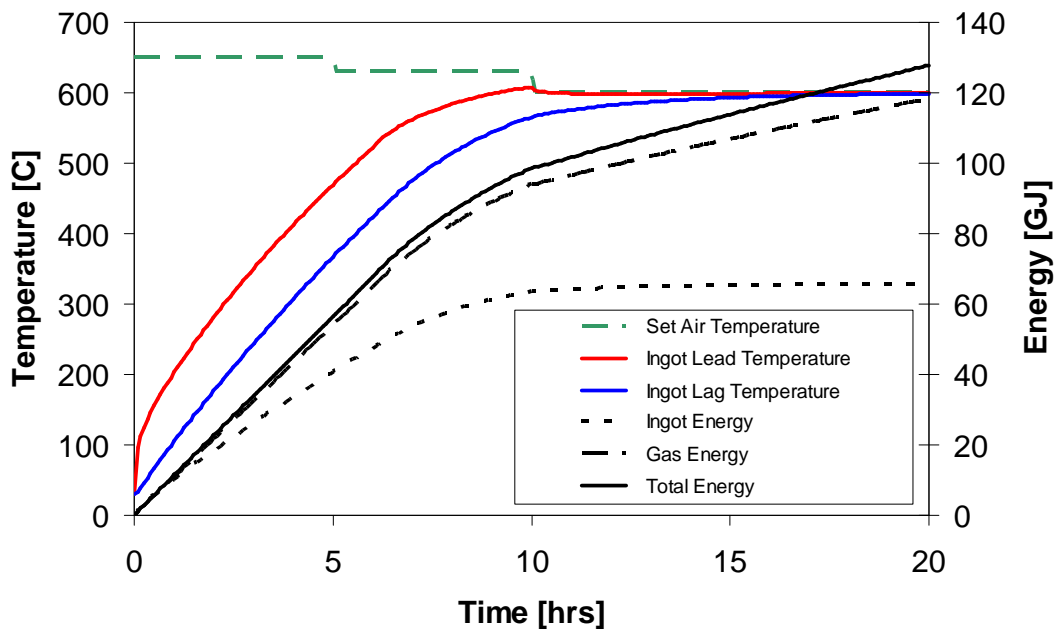

Figure 6. Ingot leading and lagging temperature and energy consumed during a typical pre-heat cycle with higher initial heated air temperature

This type of model can also be used to assess the impact of using recuperation to recover heat from the exhaust stream. For example, the model may be used to estimate the energy savings for a specific furnace and thus clarify the case for capital investment in this technology.



Summary

Many other key processes are conducted “out of sight” and Innoval has developed physics-based models to help with these processes too. Examples include the thermal annealing and quenching of plates, annealing of batch coils and continuous sheet, and the prediction of natural vibration modes of rolling mills.

Where appropriate these models can also be implemented on-line to maximise the value of the understanding contained within them. Such on-line models can provide an insight into critical variables within the process that may be impossible to measure.

These models are powerful tools to help in the optimisation of rolling processes so that maximum productivity is achieved without prejudicing product quality. Innoval has many years experience of both creating and applying this type of model.